

ROTOCADE™

PRODUCT SPECIFICATIONS

Description: Display-style, extra-tall plastic crowd-control barricade.

Size: **Height:** 42" / 44" (barricade / standing)
Width: 86" / 96" (barricade / hinge-to-hinge)
Thickness: 2.5"
Wall: .125"
Weight: 33 lbs. empty / 57 lbs. full

Display Area: 28.5" H x 36" W

Material: High Impact, UV-Resistant, Waterproof Polyethylene.

Colors: **Standard Colors:** Forest Green, Yellow.
Custom colors available.

Features: a) Extra large display area for graphics, logos and messages making it ideal for sponsors, advertisers and supporters.
b) Hollow frame that can be filled with approximately 3 gallons of water for additional stability.
c) Can be attached in various configurations.
d) Feet can rotate to allow barricade to stack flat for easy shipping and maximizing storage space.

Density: 0.950 g/cc
ASTM D-4883

Melt Index: 10.0 g/10 min
ASTM D-1238

Flexural Modulus: 140,000 psi
ASTM D-790 (Tangent Method 1)

Tensile Strength: 4,400 psi
ASTM D-638 (2" per min.)

Elongation: >800% @ Break
ASTM D-638 (2" per min.)

Heat Distortion: 75°C
ASTM D-648 (@66 psi)

Warranty: 3 years.



Signature Systems Group, LLC
50 East 42nd Street • 14th Floor
New York, NY 10017

Toll Free: 800-569-2751 • 212-953-1116 • Fax: 212-953-1117
Flooring: www.eventdeck.com • Fencing: www.signaturefencing.com

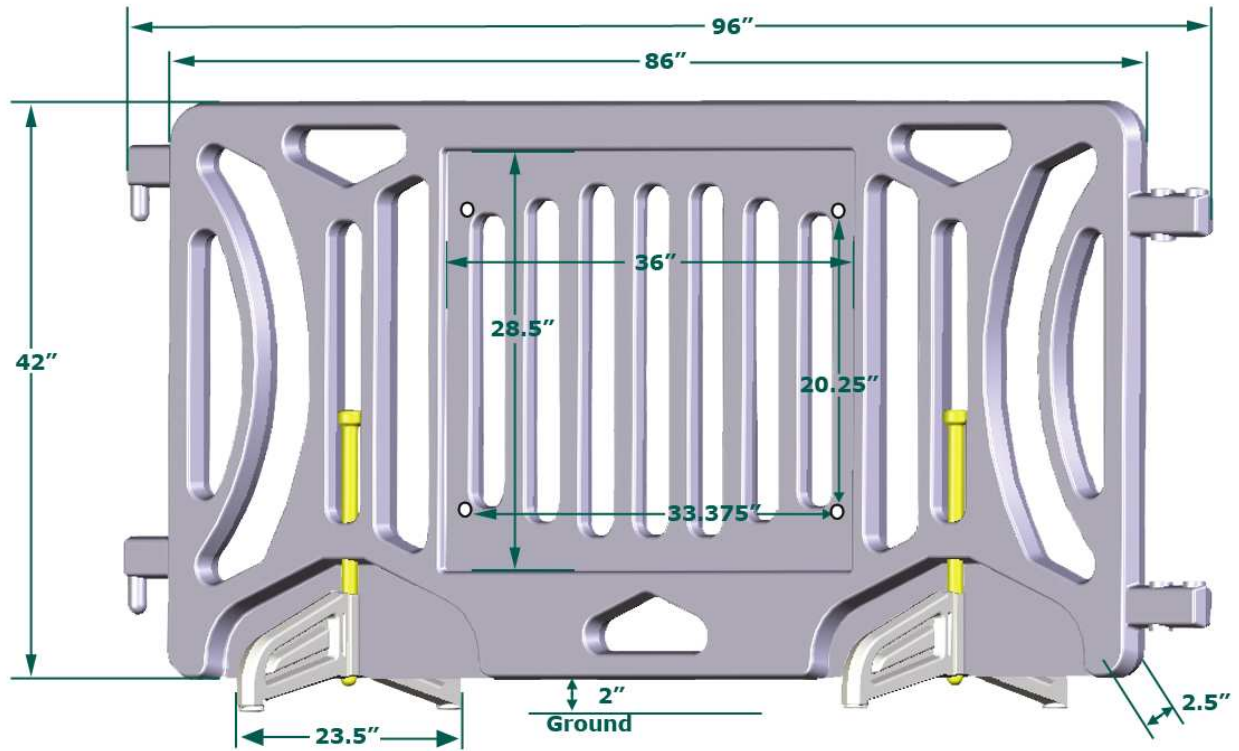

Signature Systems Group, LLC
50 East 42nd Street • 14th Floor
New York, NY 10017

Toll Free: 800-569-2751 • 212-953-1116 • Fax: 212-953-1117
Flooring: www.eventdeck.com • Fencing: www.signaturefencing.com