

WATERCADE™

WC-02 PRODUCT SPECIFICATIONS

Description:	Water-filled barricades for Traffic Safety & Construction.
Size:	Height: 42” Width: 45” Base Depth: 23.5” Wall: .156” Weight (empty): 44 lbs. Weight (full): 760 lbs. Water Capacity: 88.3 gallons
Material:	High Impact, UV-Resistant, High Density Polyethylene.
Colors:	Safety Orange and White.
Features:	a) Manufactured by a blow-molding process – producing a 2.5 times stronger product than rotational molding. b) Designed to withstand impacts up to 65 m.p.h. c) Pre-molded display area can be utilized for interchangeable signage or with reflective material to create MUTCD type I / II barricades. d) Pre-molded attachment for flashing warning lights. e) Can be utilized to create a fence or to create Type III barricades. f) Vandal-proof connection creates interlocking longitudinal walls in almost any angled configuration.
FHWA Acceptance:	WZ-200, WZ-214
NCHRP-350:	Test Level 3 – Pass
MUTCD:	6F.66
Density: ASTM D-4883	0.950 g/cc
Melt Index: ASTM D-1238	10.0 g/10 min
Flexural Modulus: ASTM D-790 (Tangent Method 1)	165,000 psi
Tensile Strength: ASTM D-638 (2” per minute)	4,390 psi
Elongation: ASTM D-638 (2” per minute)	> 800% @ Break
Heat Distortion: ASTM D-648 (66 psi)	70° Celsius

ACCESSORIES

Warning Lights:

WC-L1:

- Compatible with WC-01-10, WC-01-24, WC-02
- Solar warning light (360°)
- Lens – High impact polycarbonate
- Color – Red
- 5.5” H, 5.25” W, 10.8 oz
- Runs for 72 hrs (when fully charged)
- Flashes 65+/-10 times per minute for temperatures between -4° F to 149° F (-20° C to 65° C)

WC-L2:

- Compatible with WC-01-24, WC-02 & WC-03
- Solar hazard flashing light (2 sided)
- Lens – Shock resistant heavy-duty polycarbonate plastic
- Color – Red or Amber
- 13.5” H, 8” lens diameter, 8.3 oz
- Brightness – High brightness LED 6000 mcd
- Runs for 110 hrs (when fully charged)
- Flashes 65+/-10 times per minute for temperatures between -20° F to 150° F (-29° C to 66° C)

Warranty:

3 years.

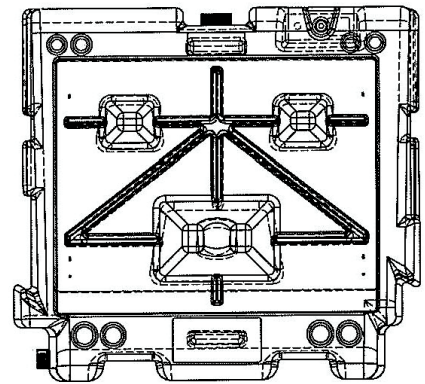
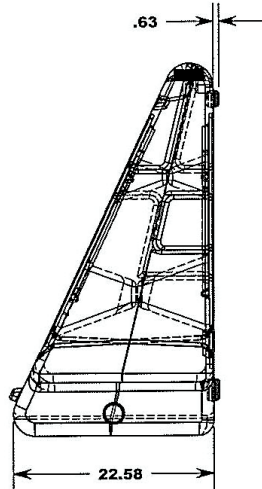
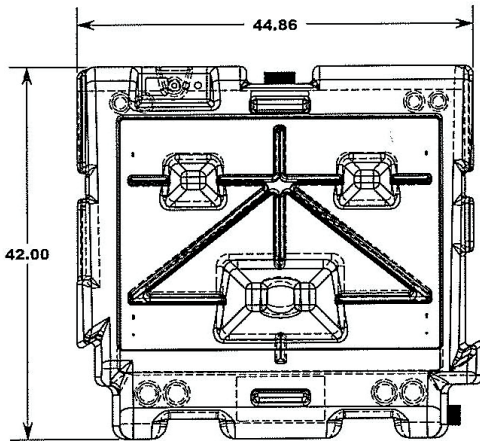
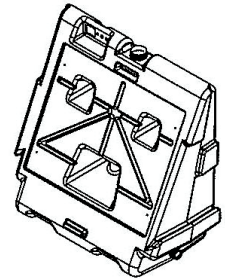
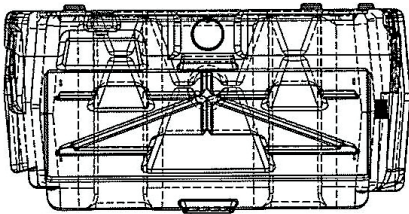

Signature Fencing & Flooring Systems, LLC

50 East 42nd Street • 14th Floor

New York, NY 10017

Toll Free: 800-569-2751 • 212-953-1116 • Fax: 212-953-1117

Flooring: www.eventdeck.com • Fencing: www.signaturefencing.com